

OPERATING GUIDE

Pulse Controller 10 Series

Installation

Operation

Product Maintenance

INSTALLATION

Mechanical Installation

View of mechanical fastening points on rear of enclosure

Note: Figure not drawn to scale

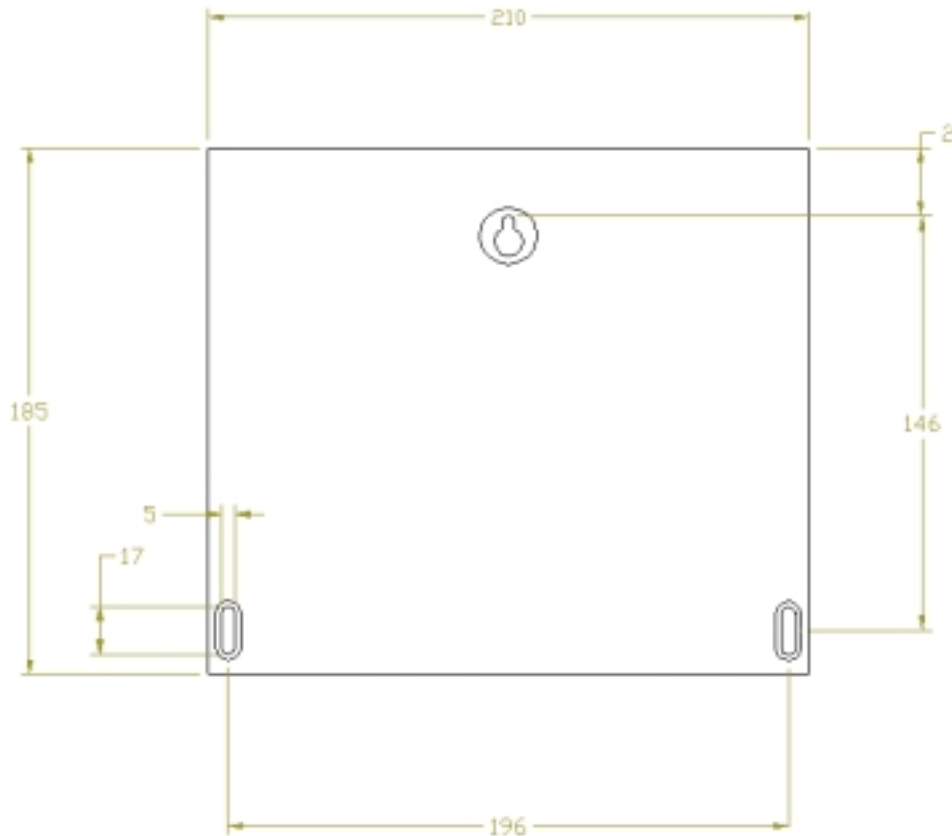

- Mount in environments of -10°C to +50°C
- Do not mount directly to hot surfaces
- Do not expose directly to sunlight
- Protect from infiltrations of water and humidity
- Do not install on vibrating surfaces
- All electrical connections including the wiring associated with the valves should not be in close proximity to wiring for other applications (for example from motor cables)
- 3 point mounting

Electrical Installation

Basic Installation

Firstly, the power should be isolated from the unit, and have the power switch in the "O" (OFF) position.

Figure 1 - Electrical circuit board with jumper selections magnified

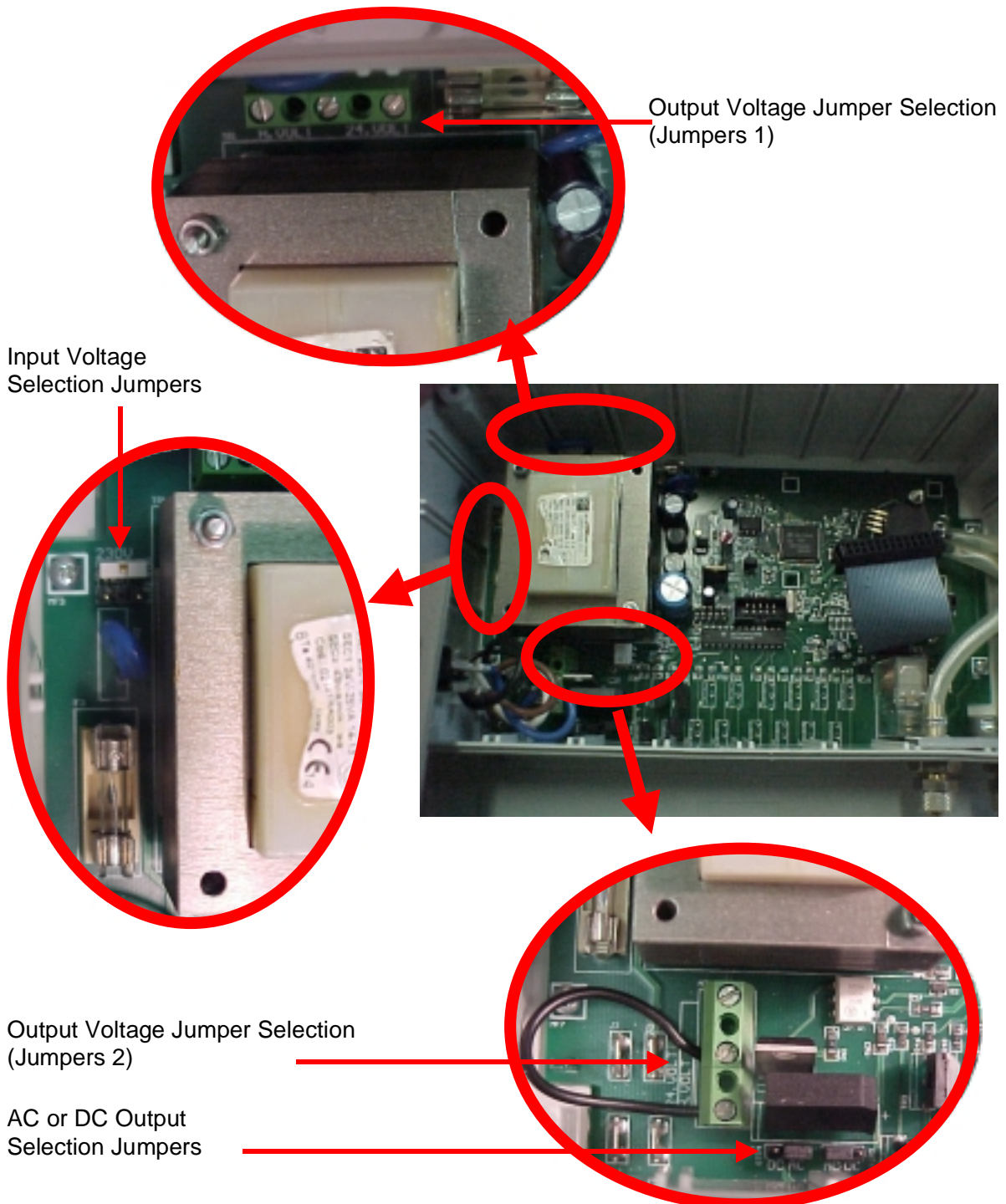

Select the input voltage being supplied to the unit by use of the jumper terminals shown in Figure 2. (Refer to Figure 1 for location on the PCB)

Figure 2 - Possible input voltage jumper selections

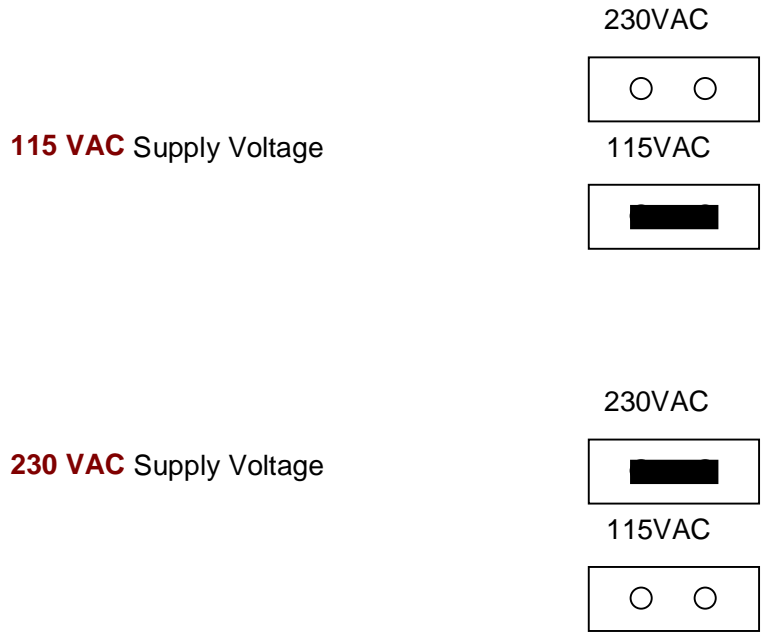

Select the output voltage being supplied to the unit by use of the jumper terminals shown in Figure 3. (Refer to Figure 1 for location on the PCB)

Figure 3 - Possible output voltage jumper selections (Jumpers 1)

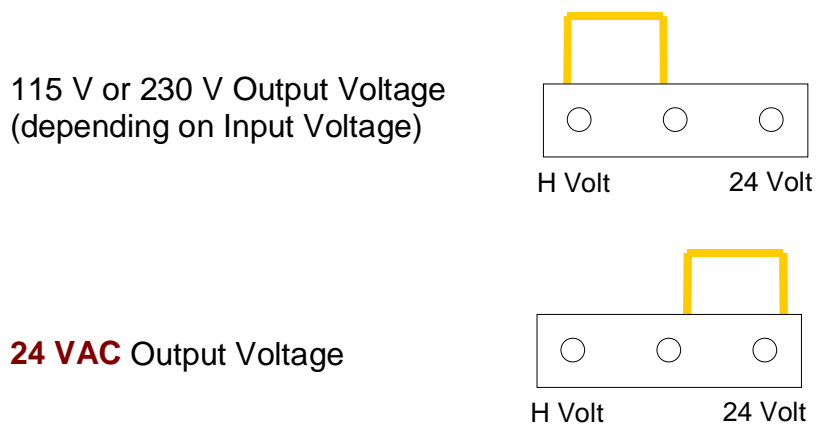

Important Note: It is of the utmost importance that when setting the Output Voltage for the controller, that the two (2) sets of jumpers shown in Figure 3 and 4 are both set to the same Output Voltage.

Figure 4 - Possible output voltage jumper selections (jumpers 2)

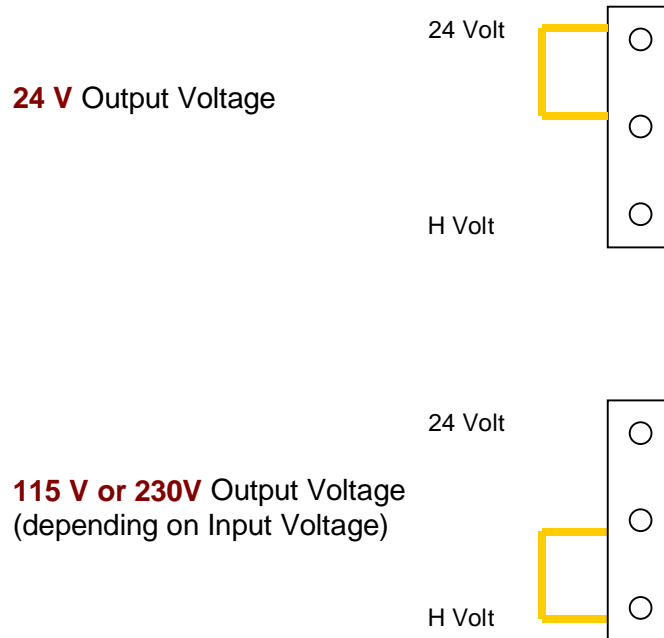

Choose whether the output is to be either AC or DC. (See Figure 5 for selections and refer to Figure 1 for location on the PCB)

IMPORTANT NOTE: NEVER select 230V Output as DC!

Figure 5 - Possible AC/DC voltage output jumper selections

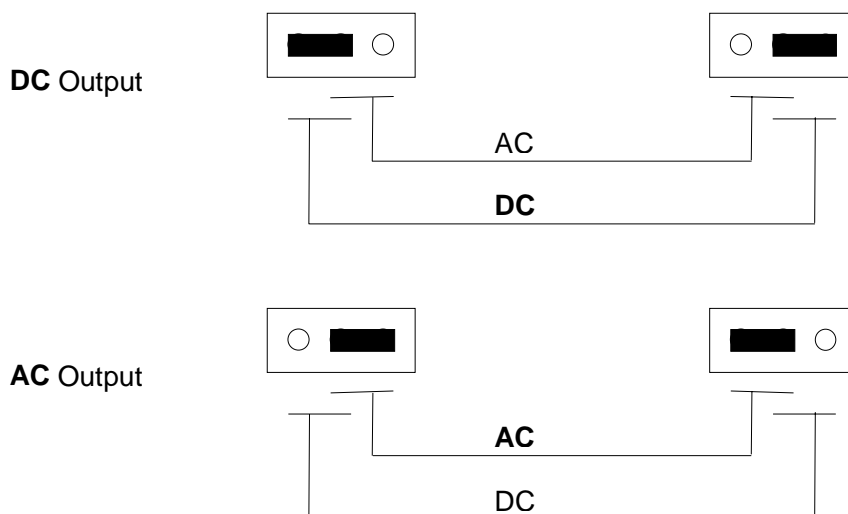

Connect the valves to the terminals shown in Figure 6.

Figure 6 - Output terminals for solenoids



Ensure that the unit is still isolated from the power supply.

Now connect the input power to the unit, observing that Ground (Yellow/Green wire) is connected properly, followed by Neutral (Blue wire) and finally Line (Brown wire).

When power is applied to the unit, turn the unit on ("I" Position).

Additional Wiring Features

This section explains the wiring of the following features of the Goyen Pulse Controller 10 Series.

- a. Fan Contacts
- b. Remote Contacts

a: Fan Contacts

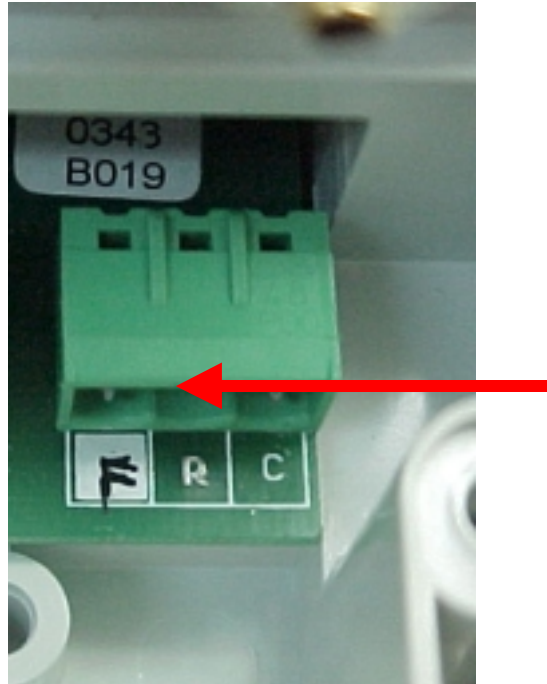

The arrow indicates the terminal connections for the Fan

It is not necessary to power this contact. If the Fan terminal is connected to ground, the unit will begin the After Cleaning Cycle. This terminal can be connected to a switch as shown in Figure 7.

Figure 7 - Fan contacts

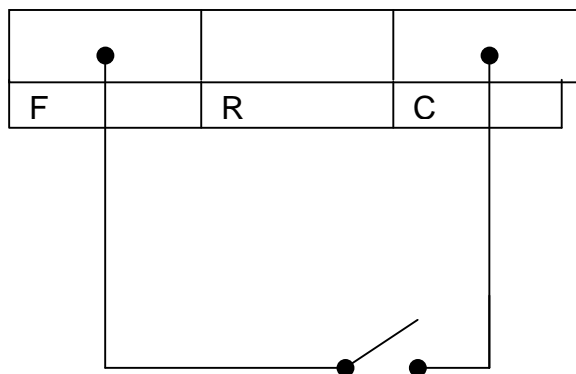

b: Remote Contacts

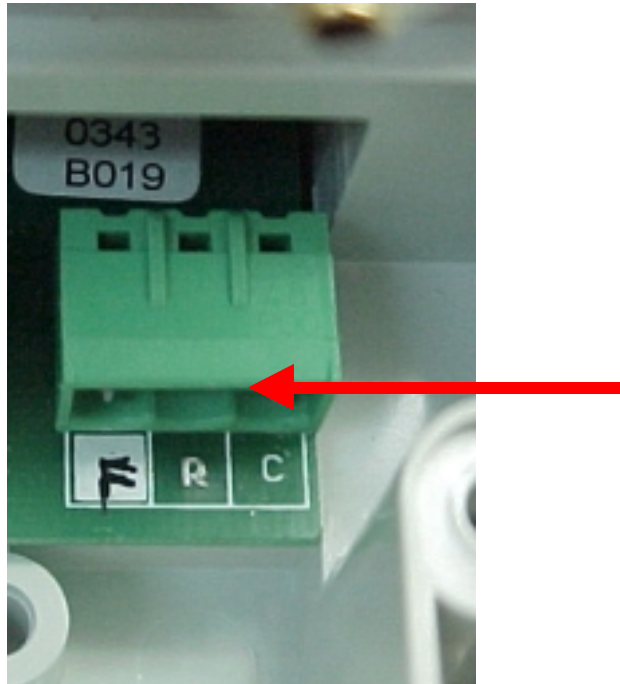

The arrow indicates the terminal connections for the Remote Contacts

It is not necessary to power this contact. If the Remote terminal is connected to ground, the unit will begin to operate. This terminal can be connected to a switch as shown in Figure 8.

Figure 8 - Remote contacts

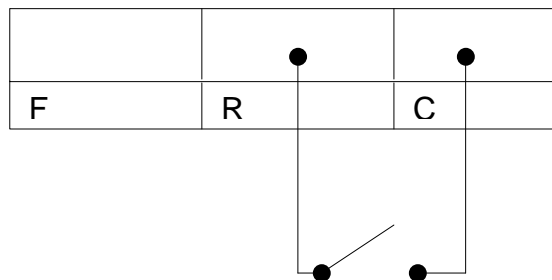

OPERATION

Electrical Pulse times

- Pulse Time (0.01 - 9.99 sec)
- Pause Time (1 - 999 sec)
- Shut Down Cleaning (0 - 99 cycles)

User Operation

The LED panel has a maximum of 3 characters with 5 LED's that each have two states.

The LED panel displays the relevant value of each of the 5 programmable variables. The particular programmable variable is indicated by use of the LED's.

LED	State	Meaning of LED Panel Display
1	Steady ON	Pulse Time (0.01 - 9.99 sec) The electrical on time of the valves
2	Steady ON	Pause Time (1 - 999 sec) The time that the system will pause between firing the valves
3	Steady ON	Number Valve Selection The number of valves on the system
4	Steady ON	Shut Down Cleaning (0 - 99 cycles)

The number of cycles to be performed after the fan switch has been switched off (provided the Fan contact is closed)

PRODUCT MAINTENANCE

- Mount in environments of -10°C to 50°C
- Do not directly expose to sunlight
- Do not mount directly to hot surfaces
- Protect from infiltrations of water and humidity
- Do not install on vibrating surfaces
- All the electrical connections including the wiring associated with the valves should not be in close proximity to wiring for other applications (for example from motor cables).